

Gorenje Built In Fridge / Freezer NRKI4181E1

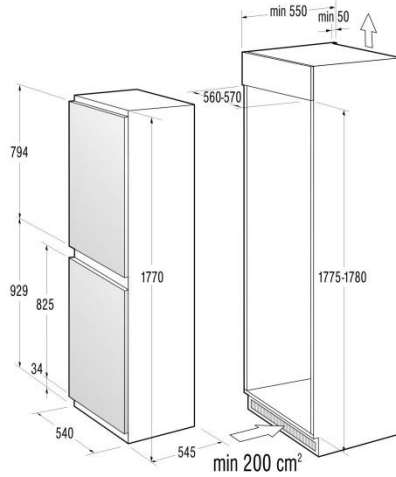

- Bottle trap
- Super cool
- 3 Glass shelves
- 1 crisper
- Antibacterial protection
- Illuminated interior
- **Colour White**
- 5 Years Guarantee on Motor
- 3 Years Parts and Labour

A+ Class

- **Automatic** Defrost process fridge section
- **Automatic** Defrost process freezer section
- Fast cooling
- Reversible door hinge
- Cover door installation system
- **Fan Forced Cooling**
- Color **White**
- Material door **White**
- Number of compressors **1**
- Approval certificates **HR,CE,UA,GOST,CPB**
- Length of electrical supply cord (cm) **205,0 cm**
- Plug type **Euro**
- **3 Drawer Freezer**
- **Bottle Holders**
- Connection Rating (W) **115 W**
- Current (A) **10 A**
- Voltage (V) **220-230 V**
- Frequency (Hz) **50 Hz**
- Total unit gross capacity (l) **269 l**
- Total unit net capacity (l) **248 l**
- Refrigerator Gross capacity (l) **183 l**
- Freezer Gross capacity (l) **86 l**
- Star Rating **4**
- Number of independent cooling systems **1**
- **Dimensions of product** W(mm) **540** H x **1772** x D **545**
- Dimensions of the packed product (mm) **1835 X 585 X 650**
- Gross weight (kg) **71,0 Kg**

Energy / Performance

- **A+ Class**
- R600A Gas
- 4 Star Rating
- Energy Efficiency A Class
- Total annual energy consumption (kWh) **293 kWh/a**
- Refrigerator Net capacity (l) **180 l**
- Freezer Net capacity (l) **68 l**
- Freezing capacity (kg) **8 Kg**
- Storage Period in Event of Power Failure (h) **16 h**
- Noise level (dB(A) re 1 pW) **39dB(A) re 1 pW**