

## Gorenje Built In Upright Freezer FNI5182A1UK



### BASIC INFORMATION

• Brand	Gorenje
• Commercial code	FNI5182A1UK
• Internal article number	728889
• EAN code	3838782052149
• Product category	Upright Freezer
• Installation type	Built In
• Type of control	Electronic
• Door opening:	Reversible door opening
• Door material:	Steel sheet
• Door hinge :	Door to door hinge
• Climate class:	SN, N, ST, T
• Total gross/net volume:	235 / 212 l
• 7 glass shelves	
• Freezing compartment:	1 door, 7 drawers
• SpaceBox	38 l.
• Dimensions (W×H×D):	55.5 × 177.2 × 54.5 cm

### FEATURES

- Electronic control
- Type of display: LED display
- Automatic defrost freezer
- Temperature indicator: Digital indicator
- Sound alarm for open door
- NoFrost
- FastFreeze
- Illuminated interior of freezer compartment: LED light

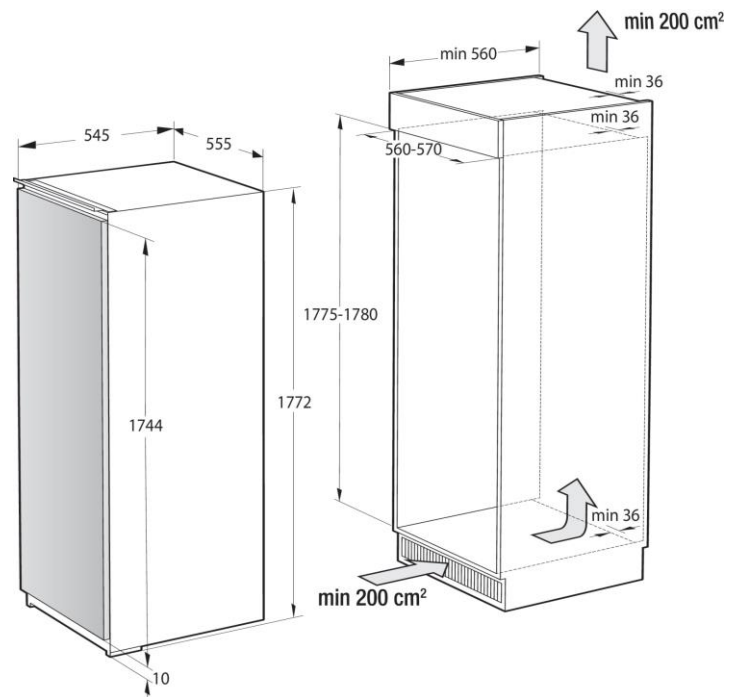

### Energy / Performance

- Energy consumption kWh/24h: 0.67 kWh
- Level of noise (max.): 39 dB(A)re 1 pW
- Freezing capacity in 24 hours: 10 kg
- Power cut safe time: 20 h
- Net weight: 69 kg
- Gross weight: 71.5 kg
- Connection rating: 80 W
- Nominal current of fuse: 13 amp