

Gorenje Built In Electric OVEN  
BO73cli- 423100

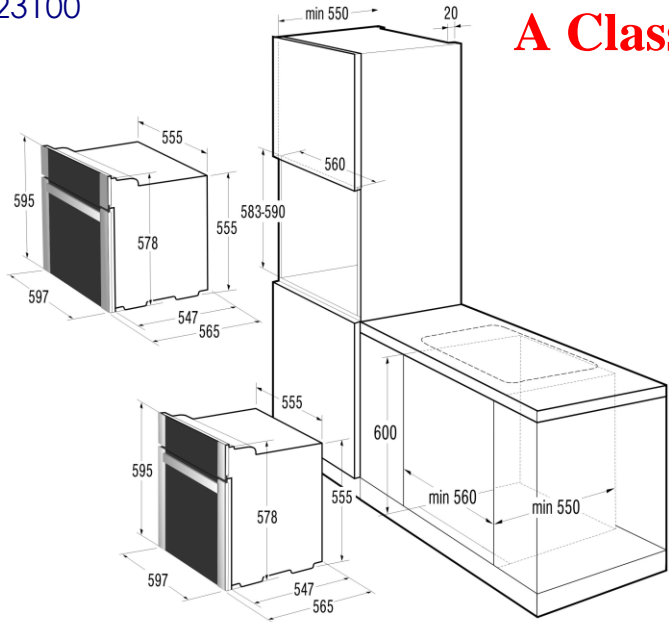

**A Class**



Features

- Cooking method **Multi-function**
- Oven interior / Temperature control **Electronic**
- Time control **Electronic**
- Integrated Cleaning system
- Interior lights **1**
- Grids **1**
- **Deep baking pan - 1**
- **Baking tray EM - 1**
- **Glass baking pan - 1**
- **Tray handle - 1**
- **Fast pre-heating**
- Eko Clean enamel
- Variable grill
- Timer clock
- Ultra cool door
- Color / Material front **cream**
- **Push Pull Knobs**
- Pan holder
- Installation type **Built-in**
- Control panel material **cream**
- Door Material **Glass / cream**
- Energy input **Electricity**
- Gas connection rating (W)/ Electrical connection rating (W)**3300 W**
- Current (A)/ Voltage (V)**230 V**
- Frequency (Hz)**50 Hz**
- **Supply cord 3 x 1.5**
- Cooling fan **Dynamic oven cooling plus DCS+**
- Flap grill
- Oven guides **Three level telescopic 3D**
- **5 Years Guarantee Parts and Labour**
- Pan holder

Energy / Performance

- Dimensions of the product (mm)**595 X 597 X 565**
- Dimensions of the packed product (mm)**691 X 635 X 680**
- Required niche size for installation (mm)**590 X 560 X 550**
- Net weight (kg)**30,0 Kg**
- Gross weight (kg)**35,3 Kg**
- Energy efficiency class - **A -20%**
- Energy consumption conventional (kWh) - **0,87 kWh**
- Energy consumption forced air convection (kWh) - **0,79 kWh**
- Useable volume (of cavity) - cavity **65,0 Litres**
- Product size - cavity **1 Large**
- Noise - **46 db(A)re 1 pW**