

## TELEFUNKEN Built In Electric OVEN TLK65-FG

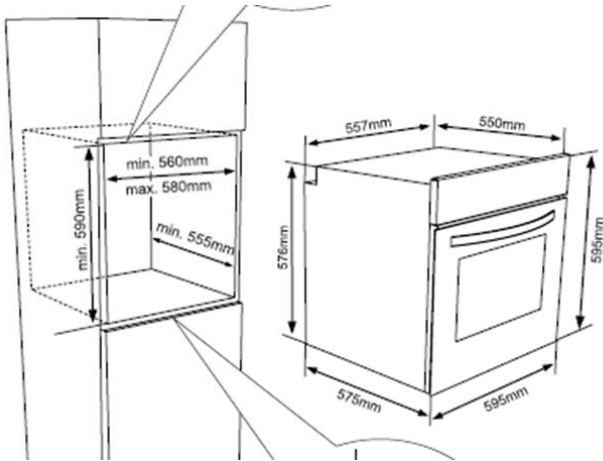

**A Class**

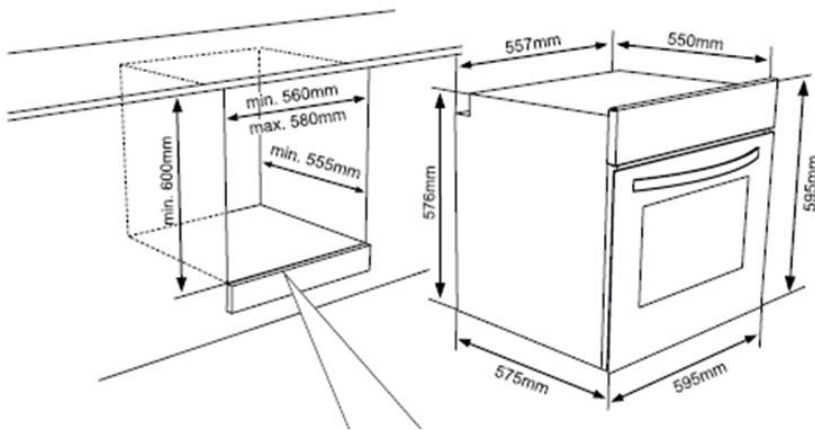

### Features

- Cooking method **Multi-function**
- Integrated Cleaning system
- Interior lights **1**
- Grids **1**
- **Baking tray EM – 1**
- **Fast pre-heating**
- Eko Clean enamel
- Variable grill
- Color / Material front **Inox**
- Pan holder
- Installation type **Built-in**
- Control panel material **Inox**
- Door Material **Glass / Inox**
- Energy input **Electricity**
- Gas connection rating (W)/ Electrical connection rating (W)**2300 W**
- Current (A)/ Voltage (V)**230 V**
- Frequency (Hz)**50 Hz**
- **Supply cord 3 x 1.5**
- **2 Years Guarantee Parts and Labour**

### Energy / Performance

Dimensions of the product (mm)**595 X 597 X 565**  
 Dimensions of the packed product (mm)**691 X 635 X 680**  
 Required niche size for installation (mm)**590 X 560 X 550**  
 Net weight (kg)**35,0 Kg**  
 Gross weight (kg)**39,3 Kg**

Energy efficiency class - **A**  
 Energy consumption conventional (kWh) - **0,79 kWh**  
 Useable volume (of cavity) - cavity **Medium**  
 Product size - cavity **1 Medium**